

Inverter Heat Pump for Swimming Pools		ACIQ110
Location: _____ Engineer: _____ Submitted to: _____ Submitted by: _____ Reference: _____	Approval: _____ Date: _____ Construction: _____ Unit #: _____ Drawing #: _____	

Set Code	
Set Model	ACIQ110
Outdoor unit model	
Certified	AHRI CSA



SYSTEM PERFORMANCE DATA			
Electrical			
Power Supply	(V, Ph, Hz)	208/230V, 1Ph, 60Hz	
Fuse	(A)	40	
Power Cord	(AWG)	2x8	
Operating Temperature			
		(°F)	32°F-109°F
Max. Pool Capacity			
		(Gal)	≤ 32000
		(L)	≤ 120000
Air Input Capacity (80°F)			
		(A)	2.65 - 25.6
		(kW)	0.61 - 5.9
Advised Water Flux			
		(L/min)	133 - 167
Sound Pressure at 3m			
		(dB(A))	35.5 - 49.5
Noise at 10 ft.			
		(dB(A))	≤ 50
Heating Capacity			
Conditions: Air 80°F / Water 80°F / Humidity 80°F			
Heating Capacity	(Btu/h)	110000	
Heating Capacity (Silent Mode)	(Btu/h)	88000	
COP	(W/W)	13.5 - 5.8	
Conditions: Air 80°F / Water 80°F / Humidity 63°F			
Heating Capacity	(Btu/h)	104000	
Heating Capacity (Silent Mode)	(Btu/h)	83500	
COP	(W/W)	12.2 - 5.6	
Conditions: Air 50°F / Water 80°F / Humidity 63°F			
Heating Capacity	(Btu/h)	67000	
Heating Capacity (Silent Mode)	(Btu/h)	54000	
COP	(W/W)	5.2 - 4.2	

UNIT SPECIFICATIONS & DIMENSIONS		
Casing	-	ABS + Metal
Air Discharge	-	Vertical
Water Pipe In-Out Dimensions	(in)	2"
Unit Dimensions (WxDxH)	(in)	37.2 x 27.3 x 38.5
Net Weight	(lbs)	251
Heat Exchanger	-	Titanium PVC
Waterproof Class	-	IPX4
REFRIGERANT DATA		
Refrigerant Type	-	R410A
Charge Amount	(oz)	141.0
Design Pressure (High)	(PSIG)	≤609
Design Pressure (Low)	(PSIG)	≤261
WARRANTY DATA		
Parts & Labor	-	3 years
Exchanger & Compressor	-	5 years

Unit Dimensions

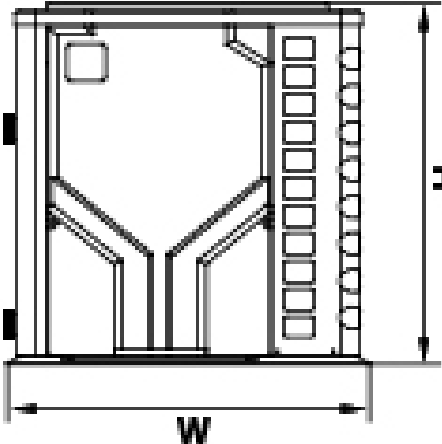
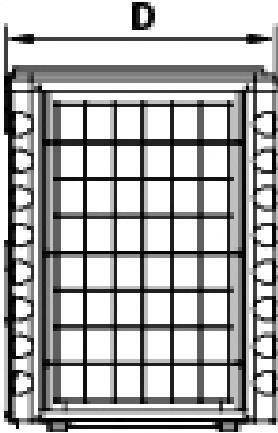
Size(inch) / Name	W (Width)	D (Depth)	H (Height)
Model			
ACIQ110	37.2	27.3	38.5