



SUBMITTAL DATA SHEET

9K (115V) Single-Zone Mini Split System

Location: _____
 Engineer: _____
 Submitted to: _____
 Submitted by: _____
 Reference: _____

Approval: _____
 Date: _____
 Construction: _____
 Unit #: _____
 Drawing #: _____

Set Model	Indoor unit model	ACIQ-K09W-HP115
	Outdoor unit model	ACIQ-K09Z-HP115
Certified	AHRI	
	UL	



SYSTEM PERFORMANCE DATA

Power supply		
Normal Operational Voltage	(V, Ph, Hz)	115V, 1Ph, 60Hz
Electrical		
Minimum circuit ampacity (Outdoor)	(A)	17
Max.fuse (Outdoor)	(A)	25
Connection wiring	Size x Core Number	4x16AWG
Max Current (T1)	(A)	10
Current Range	(A)	2.7-8.7
Cooling		
Rated Cooling Capacity at 95°F (35°C)	(Btu/h)	9000
Rated Input Consumption	(W)	840
Rated Current	(A)	7.4
SEER2 at 95°F (35°C)	(Btu/W.h)	19.0
EER2 at 95°F (35°C)	(Btu/W.h)	10.0
Heating		
Rated Heating Capacity at 47°F (8.3°C)	(Btu/h)	10000
Rated Input Consumption	(W)	810
Rated Current	(A)	7.2
HSPF2-4	(Btu/W.h)	8.5
HSPF2-5	(Btu/W.h)	7.0
COP2 at 47°F (8.3°C)	W/W	3.41
COP2 at 5°F (-15°C)	W/W	1.75
Max. Heating Capacity at 5°F (-15°C)	(Btu/h)	7200 (72%)

REFRIGERANT PIPE DATA

Maximum Operation Pressure	(PSIG)	550
Refrigerant Type		R410A
Refrigerant precharge	(ft)	25.0
	(m)	7.5
Additional charge for each ft	(oz/ft)	0.22
Additional charge for each m	(g/m)	20.0
Liquid side/ Gas side (indoor)	(inch)	1/4"/3/8"
	(mm)	6.35/9.52
Liquid side/ Gas side (outdoor)	(inch)	1/4"/3/8"
	(mm)	6.35/9.52
Max. line length	(ft)	50.0
	(m)	15.0
Max. difference in level	(ft)	33.0
	(m)	10.0
Connection method	Type	Pre-Charged Line Set
Operating Temperature	(Deg. °F)	61° ~ 88°
	(Deg. °C)	16° ~ 31°
Ambient Temperature		
Indoor (cooling)	(Deg. °F)	≥ 62°
	(Deg. °C)	≥ 17°
Indoor (heating)	(Deg. °F)	≤ 86°
	(Deg. °C)	≤ 30°
Outdoor (cooling)	(Deg. °F)	5° ~ 122°
	(Deg. °C)	-15° ~ 50°
Outdoor (heating)	(Deg. °F)	-4° ~ 86°
	(Deg. °C)	-20° ~ 30°

INDOOR UNIT DATA

Airflow & Noise level		
Indoor airflow (Hi/Med/Lo)	(CFM)	353/288/250
	(m3/h)	600/490/425
Indoor noise level (Turbo/Hi/Med/Lo/Mute)	dB(A)	41/39/34/29/26
Suitable Room Coverage Area	sq. ft.	Up to 400
Dehumidification		
	(Liters/Hr)	1.1
Unit & Packing Dimensions		
Unit Dimensions (WxDxH)	(inch)	31.92x11.49x8.07
	(mm)	811x292x205
Packing Dimensions (WxDxH)	(inch)	34.84x14.40x10.94
	(mm)	885x366x278
Net/Gross Weight		
Net/Gross weight (w/o accessories)	(lbs.)	20.9/25.4
	(kg)	9.5/11.5
Net/Gross weight (w/ all accessories)	(lbs.)	23.8/28.0
	(kg)	10.8/12.7

OUTDOOR UNIT DATA

Airflow & Noise level		
Outdoor airflow (Max.)	(CFM)	1120
	(m3/h)	1900
Outdoor noise level	dB(A)	51
Unit & Packing Dimensions		
Unit Dimensions (WxDxH)	(inch)	28.14x11.42x19.61
	(mm)	715x290x498
Packing Dimensions (WxDxH)	(inch)	32.20x12.80x21.18
(w/o 5m pipe)	(mm)	818x325x538
Packing Dimensions (WxDxH)	(inch)	33.00x13.31x21.65
(w/ 5m pipe)	(mm)	838x338x550
Packing Dimensions (WxDxH)	(inch)	33.27x13.60x23.23
(w/ larger packaging & 5m pipe)	(mm)	845x345x590
Net/Gross Weight		
Net/Gross Weight (w/o 5m pipe)	(lbs.)	48.5/52.9
	(kg)	22.0/24.0
Net/Gross Weight (w/ 5m pipe)	(lbs.)	52.9/57.3
	(kg)	24.0/26.0
Gross Weight	(lbs.)	60.6
(w/ larger packaging & 5m pipe)	(kg)	27.5

Indoor Unit Dimensions

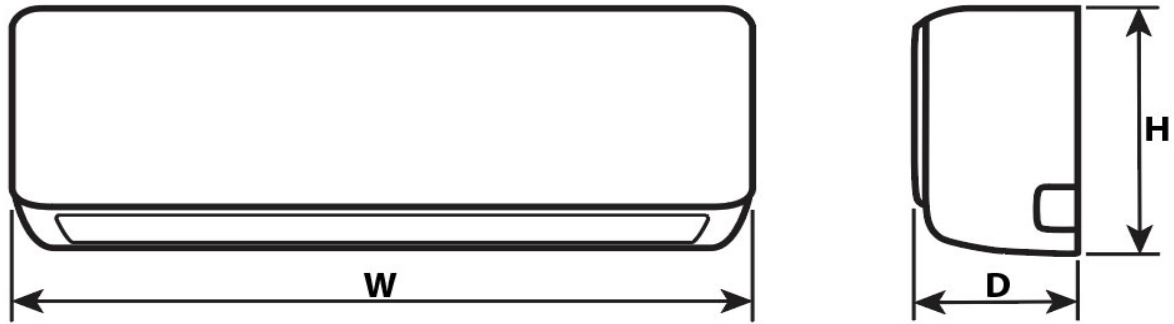

Capacity	W (Width)	D (Depth)	H (Height)
9K-12K	31.92 in (811 mm)	11.49 in (292 mm)	8.07 in (205 mm)
18K	39.76 in (1010 mm)	12.40 in (315 mm)	8.66 in (220 mm)
24K-36K	46.93 in (1192 mm)	14.17 in (360 mm)	10.23 in (260 mm)

Units: Inch (Millimeter)

Outdoor Unit Dimensions

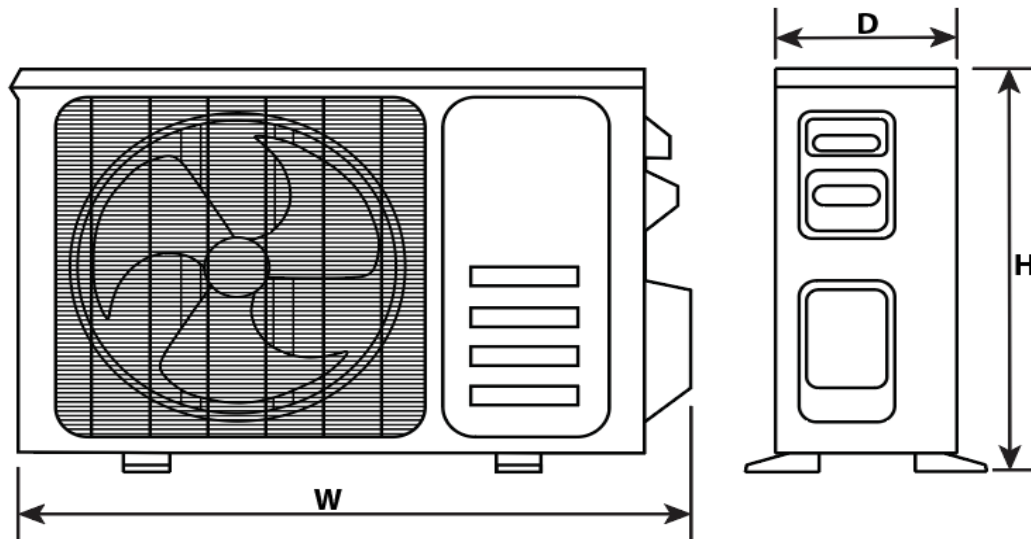

Capacity	W (Width)	D (Depth)	H (Height)
9K-12K	28.14 in (715 mm)	11.42 in (290 mm)	19.61 in (498 mm)
18K	30.70 in (780 mm)	13.74 in (349 mm)	23.81 in (605 mm)
24K	33.26 in (845 mm)	14.96 in (380 mm)	27.51 in (699 mm)
36K	35.83 in (910 mm)	16.54 in (420 mm)	31.50 in (800 mm)

Units: Inch (Millimeter)