

Models: ANP50 ANP80 ANP100

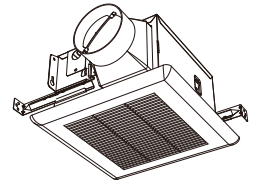

## WARNING

---

**TO REDUCE THE RISK OF FIRE, ELECTRIC SHOCK, OR INJURY TO PERSONS, OBSERVE THE FOLLOWING:**

1. Use this unit only in the manner intended by the manufacturer. If you have questions, contact the manufacturer at the address or telephone number listed in the warranty.
2. Before servicing or cleaning unit, switch power off at service panel and lock the service disconnecting means to prevent power from being switched on accidentally. When the service disconnecting means cannot be locked, securely fasten a prominent warning device, such as a tag, to the service panel.
3. Installation work and electrical wiring must be done by a qualified person(s) in accordance with all applicable codes and standards, including fire-rated construction codes and standards.
4. Sufficient air is needed for proper combustion and exhausting of gases through the flue (chimney) of fuel burning equipment to prevent backdrafting. Follow the heating equipment manufacturer's guideline and safety standards such as those published by the National Fire Protection Association (NFPA), and the American Society for Heating, Refrigeration and Air Conditioning Engineers (ASHRAE), and the local code authorities.
5. When cutting or drilling into wall or ceiling, do not damage electrical wiring and other hidden utilities.
6. Ducted fans must always be vented to the outdoors.
7. Acceptable for use over a tub or shower when connected to a GFCI (Ground Fault Circuit Interrupter) - protected branch circuit (ceiling installation only).
8. This unit must be grounded.

## CAUTION

---

1. For general ventilating use only. Do not use to exhaust hazardous or explosive materials and vapors.
2. This product is designed for installation in ceilings up to a 12/12 pitch (45 degree angle). Duct connector must point up. **DO NOT MOUNT THIS PRODUCT IN A WALL.**
3. Do not let plaster dust or any other construction residue enter the fan. During construction or renovation, cover the fan.
4. Combustible products used for cleaning such as acetone, alcohol, ether, or benzol are highly explosive and should never be used close to the fan.

## CLEANING & MAINTENANCE

---

The ventilation fan should be cleaned regularly (internally and externally) to preserve its appearance and performance. Use a dusting brush attachment to gently vacuum the exterior and interior of the ventilation fan to remove dust and

## OPERATION

---

See "CONNECT ELECTRICAL WIRING" for details.

**READ AND SAVE THESE INSTRUCTIONS**  
Installer: Leave this manual with the homeowner.

# PLAN THE INSTALLATION

1. Do not use in a cooking area.
2. Two ways to connect ductwork to a factory-shipped unit.

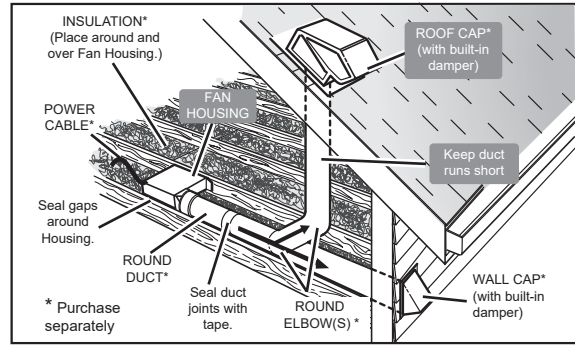
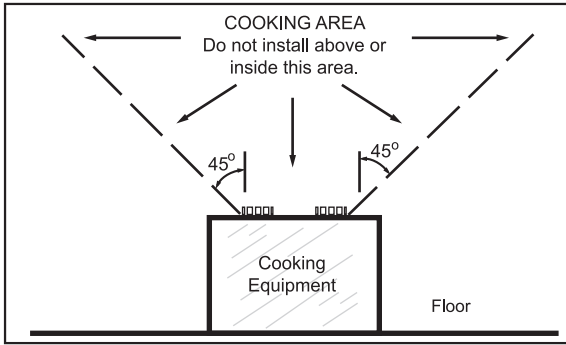

## TYPES OF TYPICAL INSTALLATIONS

1. Housing mounted to I-joists (Start at "ASSEMBLY INSTRUCTIONS 1")
2. Housing mounted to joists (Start at "ASSEMBLY INSTRUCTIONS 1")
3. Housing mounted to truss (Start at step "ASSEMBLY INSTRUCTIONS 2")

## ASSEMBLY INSTRUCTIONS

### 1. MOUNT HOUSING TO JOIST OR I-JOIST.

- a. Hold the housing so that it is in contact with the bottom of the joist.
- b. Attach the housing with four (4) screws to the joist through the holes in each mounting flange.

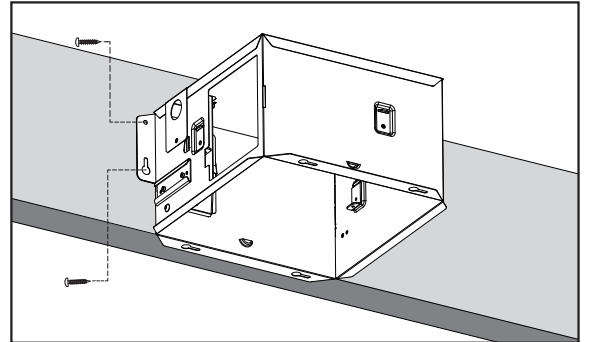

### 2. Mount with mounion holes and hanger bar

- a. Slide one hanger bar into the channel on the housing and adjust as needed to fit between framing.
- b. Hold housing in place so that the housing contact the bottom of the joist, Screw housing to joist through the hole of the housing .
- c. Screw the hanger bar onto the other side of joist through the hole.
- d. Screw hanger bar to housing with screw.
- e. Refer to the right diagram.

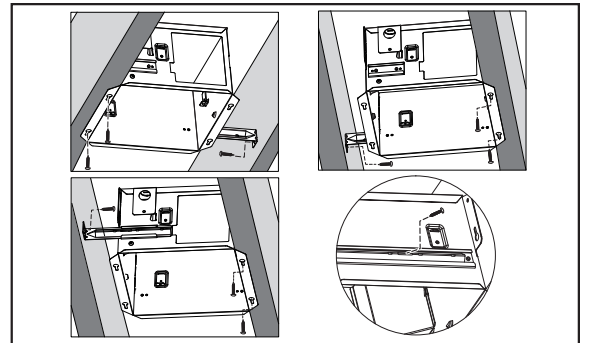

### 3. Mount to I-joist

- a. Slide one hanger bar into channel on the housing and adjust as needed.
- b. Hold housing in place so that the housing contacts the bottom of the joist.
- c. Screw housing to joist through the hole of the housing.
- d. Screw the hanger bar onto the joist through the hole.
- e. Screw hanger bar to housing with screw .

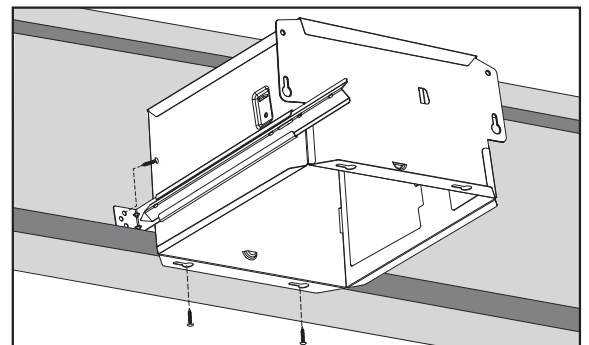

# ASSEMBLY INSTRUCTIONS

## 4. Install DUCT AND BLOWER ASSEMBLY

- a. Install duct from the inside of the housing; Fix the duct by the tab.
- b. Fix the BLOWER ASSEMBLY to the housing by 3 screws.

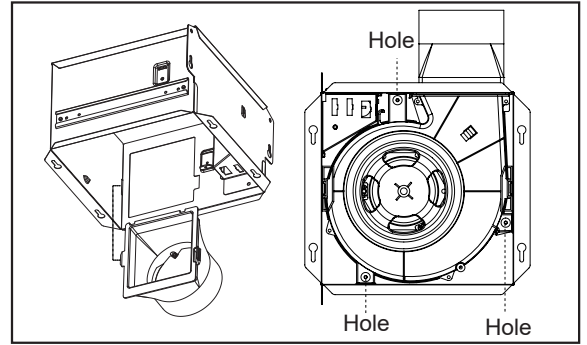

## 5. INSTALL ROUND DUCTWORK

- a. Connect the round ductwork (not included) to the damper/duct connector, and run the ductwork to a roof or wall cap (not included).
- b. Using tape (not included), secure all the ductwork connections so that they are air tight.
- c. Insulated flexible duct is recommended for the quietest possible installation. If rigid duct is used, a short (1-3 feet) section of insulated flexible duct will ensure quiet operation.

The ducting from this fan to the outside of building has a strong effect on the air flow, noise and energy use of the fan. Use the shortest, straightest duct routing possible for best performance, and avoid installing the fan with smaller ducts than recommended. Insulation around the ducts can reduce energy loss and inhibit mold growth. Fans installed with existing ducts may not achieve their rated air flow.

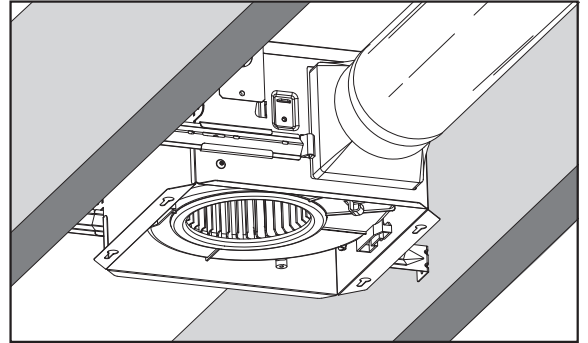

# CONNECT ELECTRICAL WIRING

Run 120 V AC house wiring to the location of the fan. Use only UL-approved connectors (not included) to attach the house wiring to the wiring plate. Refer to the wiring diagram, and connect the wires as shown.

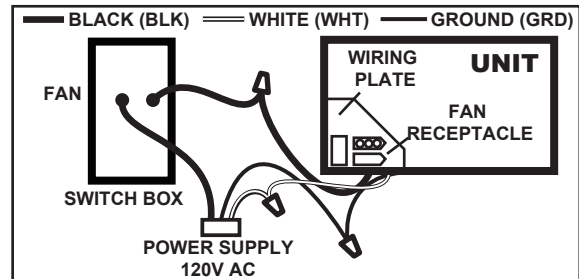
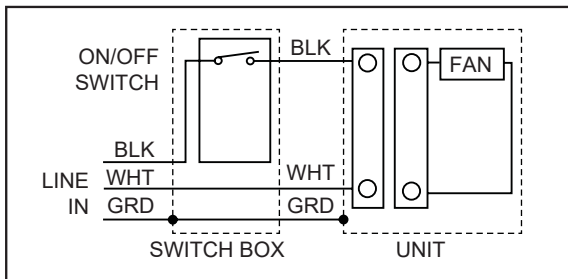

# INSTALL GRILLE

Install ceiling material to complete the ceiling construction and cut around the fan housing.

To attach the grille assembly to the fan housing, pinch the grille springs on the sides of the grille assembly and position the grille into the housing with the grille springs in the appropriate slots. Push the grille assembly towards the ceiling to secure.

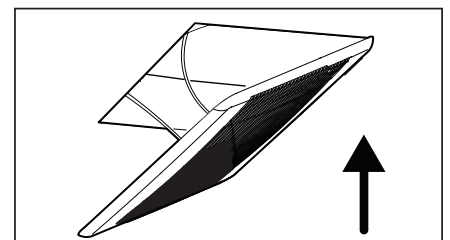

# SERVICE PARTS

PART	PART NAME	Qty.
1	Grille Assembly (includes part 2)	1
2	Grille Spring	2
3	Blower	1
4	Blower Wheel	1
5	Motor	1
6	Motor Plate	1
7	Housing	1
8	Wire Panel / Harness Assembly	1
9	Hanger Bars	4
10	Wiring Plate	1
11	Damper/Duct Connector	1
a	Screw	3
b	Screw	3
c	Screw	4
d	Screw	2

\* Blower Assembly includes part 3, 4, 5, 6, a, b, c  
 Replacement installation: Remove the screw (part a), then take out the blower assembly from the housing (part 7). Replace the broken parts.

**WARNING:** Ensure that the fan is switched off from the supply mains before replacing.

