

MODELS AEP80 AEP110 AEP150

Ultra Silent, High Performance, Attractive Design Grille

Description

- Ventilating fan should be ceiling or wall mounted and capable of exhausting air quietly and efficiently. The SE series is HVI certified.
- It comes with a capacitor start motor which is known for its high efficiency and long lasting reliability. It holds an ETL evaluation and conforms to UL and cUL safety standards.
- This fan has a unique plug and play concept that allows you to add accessories such as motion sensor, humidistat, light, or even speed/controller without changing the fan.

Housing

- Made of rugged 26 GA galvanized steel
- Detachable 6 inch polymeric resin collar which includes a light weight built in back draft damper.
- Double hanger bar mounting brackets that are adjustable up to 24 inch span allows for ideal positioning.

Motor/Blower

- Plug in permanently lubricated motor- Engineered for continuous operation.
- Power rating should be 120 volts and 60 Hz.
- Fan shall be ETL and cETL listed for tub/shower enclosure when used with a GFCI branch circuit.
- Motor comes with a built in overload disconnect for safety and longer motor life.
- Our ventilators operates at lower RPM's to give you quieter operation.

Grille

- The grille is low profile that has elegance and still able to maintain its simplicity.
- Made of a rugged polymeric resin that's known for its long life durability.
- Comes with torsion spring clips that helps mount grille evenly.

Typical specification

- Ceiling ventilator shall have corrosion resistance galvanized steel housing with 4 point mounting capability.
- It shall be ducted to a roof vent or wall cap using 6 inch round pipe.
- Blower assembly shall be removable, have a centrifugal type blower wheel and a permanently lubricated motor designed for continuous operation.
- Air and sound delivery shall meet the HVI certified ratings as per the fan curves attached.
- Ventilators come with permanent split capacitor motor which improves efficiency.



Reference	QTY.	Remarks	Project:
			Location:
			Architect:
			Engineer:
			Contractor:
			Submitted by:
			Date:

CERTIFICATIONS



Model Number	AEP80	AEP110	AEP150
Static Pressure in inches w.g.	0.1	0.1	0.1
Air Volume (CFM)	80	110	150
Noise (sones)	0.4	0.9	0.5
Fan Watts	23	30	36
Duct Diameter	6"		
Power Rating (V/Hz)	120/60		

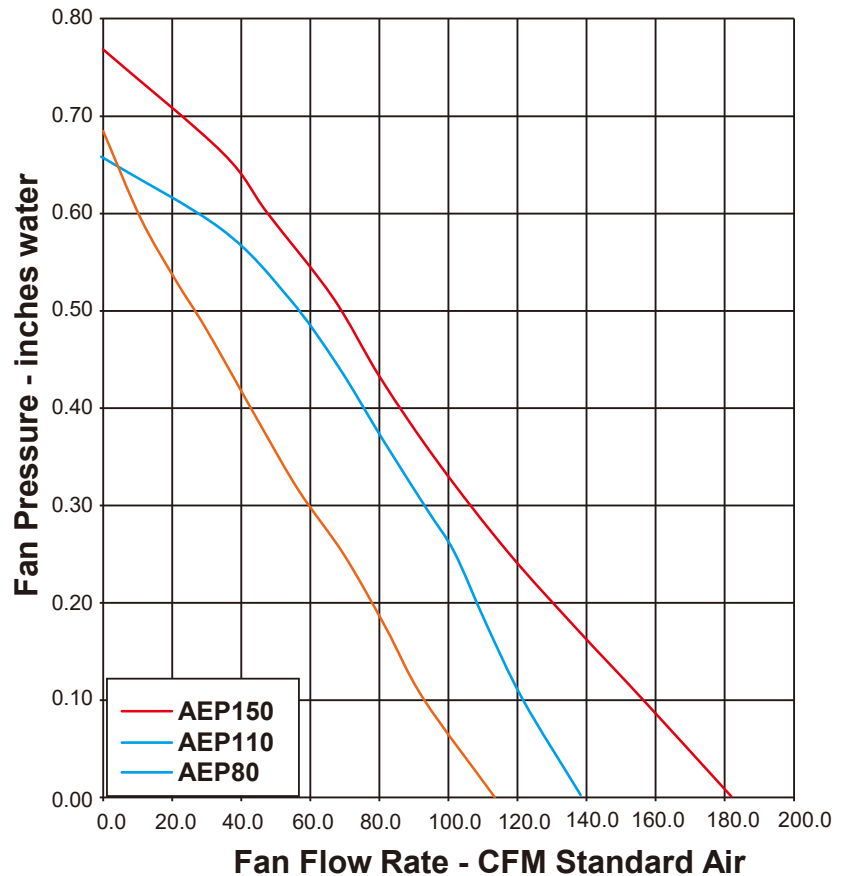
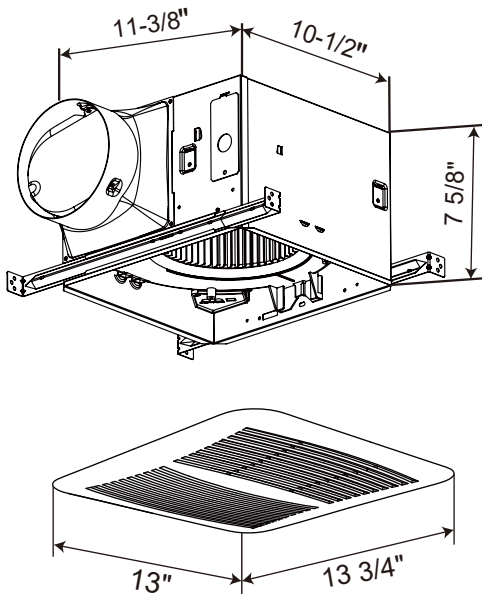

CERTIFICATIONS

