

PANCAKE Heat Pump System

Location: _____
 Engineer: _____
 Submitted to: _____
 Submitted by: _____
 Reference: _____

Approval: _____
 Date: _____
 Construction: _____
 Unit #: _____
 Drawing #: _____

Set Code		/
Indoor unit code	22023011005474	
Outdoor unit code	22023116000102	
Set Model		
Indoor unit model	ACIQ-18W-P	
Outdoor unit model	ACIQ-18-EHPB	
Certified		
AHRI		
UL		



SYSTEM PERFORMANCE DATA

Power supply		
Normal Operational Voltage	(V, Ph, Hz)	208/230V, 1Ph, 60Hz
Voltage Range	(V)	187-253
Electrical		
Minimum circuit ampacity(Outdoor)	(A)	16.0
Max.fuse(Outdoor)	(A)	20.0
Connection wiring		14AWG*2 Stranded, shielded
Cooling		
Capacity	(Btu/h)	18000
Power Input	(W)	/
Current	(A)	/
SEER2	(Btu/W)	16.0
EER2	(Btu/W)	10.0
Heating		
Capacity	(Btu/h)	18000
Power Input	(W)	/
Current	(A)	/
HSPF2-4	(Btu/W)	8.0
HSPF2-5	(Btu/W)	6.0
COP	W/W	/
Heat at 17F(H32)	(Btu/h)	12000
Heat at 5F(H42)	(Btu/h)	10000
COP at 5F(H42)	W/W	1.90

REFRIGERANT PIPE DATA

Throttle type	Indoor unit	EEV for cooling
	Outdoor unit	EEV for heating
Design pressure	(PSIG)	550/340
Refrigerant Type		R410A
Refrigerant charge	oz	56.44
Refrigerant precharge	(ft)	25.0
	(m)	7.5
Additional charge for each ft	(oz/ft)	0.69
Additional charge for each m	(g/m)	65.0
Liquid side/ Gas side(indoor)	(inch)	3/8" / 3/4"
	(mm)	9.52/19
Liquid side/ Gas side(outdoor)	(inch)	3/8" / 5/8"
	(mm)	9.52/16
Max. pipe length	(ft)	98.4
	(m)	30.0
Max. difference in level	(ft)	65.6
	(m)	20.0
Connection method		Flared
Indoor(cooling)	(Deg. °F)	60~90
	(Deg. °C)	16~32
Indoor(heating)	(Deg. °F)	32~86
	(Deg. °C)	0~30
Outdoor(cooling)	(Deg. °F)	5~122
	(Deg. °C)	-15~50
Outdoor(heating)	(Deg. °F)	-13~75
	(Deg. °C)	-25~24

INDOOR UNIT DATA

Indoor fan motor		
Model		ZKFD-250-10-2
Qty		1
Input	(W)	/
Output	(W)	/
RLA	(A)	3.8
Speed(Hi/Mi/Lo)	(r/min)	/
Air flow & Noise level		
Indoor air flow (Hi/Med/Lo) (No duct)	(CFM)	600.00/564.71/529.41/488.24
Indoor noise level (Hi/Med/Lo)	[dB(A)]	54/50/45.5
Dehumidification	(L/H)	0
Indoor unit		
Dimension (WxDxH)	(inch)	43.23x23.33x10.93
	(mm)	1098x592.7x277.6
Packing(WxDxH)	(inch)	47.24x26.77x13.58
	(mm)	1200x680x345
Net/Gross weight	(lbs.)	112.43/124.78
	(kg)	51/56.6
Accessories		
Adaptor for welding(3/4")	Qty	1
Adaptor for welding(3/8")	Qty	1

OUTDOOR UNIT DATA

Compressor		
Type		ROTARY
Model		KSN140D21UFZ
Brand		GMCC
Capacity	(Btu/h)	14962
Input	(W)	1140
Rated current (RLA)	(A)	9
Refrigerant oil/oil charge	(ml)	VG74 440
Outdoor fan motor		
Model		ZKFN-34-10-1-3
Qty		1
Input	(W)	/
Output	(W)	/
RLA	(A)	1.0
Speed	(r/min)	840/700/650
Air flow & Noise level		
Outdoor air flow (Max.)	(CFM)	1450
Outdoor noise level	[dB(A)]	55.0
Outdoor unit		
Dimension (WxDxH)	(inch)	31.69x12.99x21.81
	(mm)	805x330x554
Packing (WxDxH)	(inch)	36.02x14.57x24.21
	(mm)	915x370x615
Net/ Gross weight	(lbs.)	75.84/81.35
	(kg)	34.4/36.9
Accessories		
Adaptor for welding(3/4")	Qty	1
Adaptor for welding(3/8")	Qty	1
Adaptor (5/8" to 3/4")	Qty	1

Indoor unit dimension

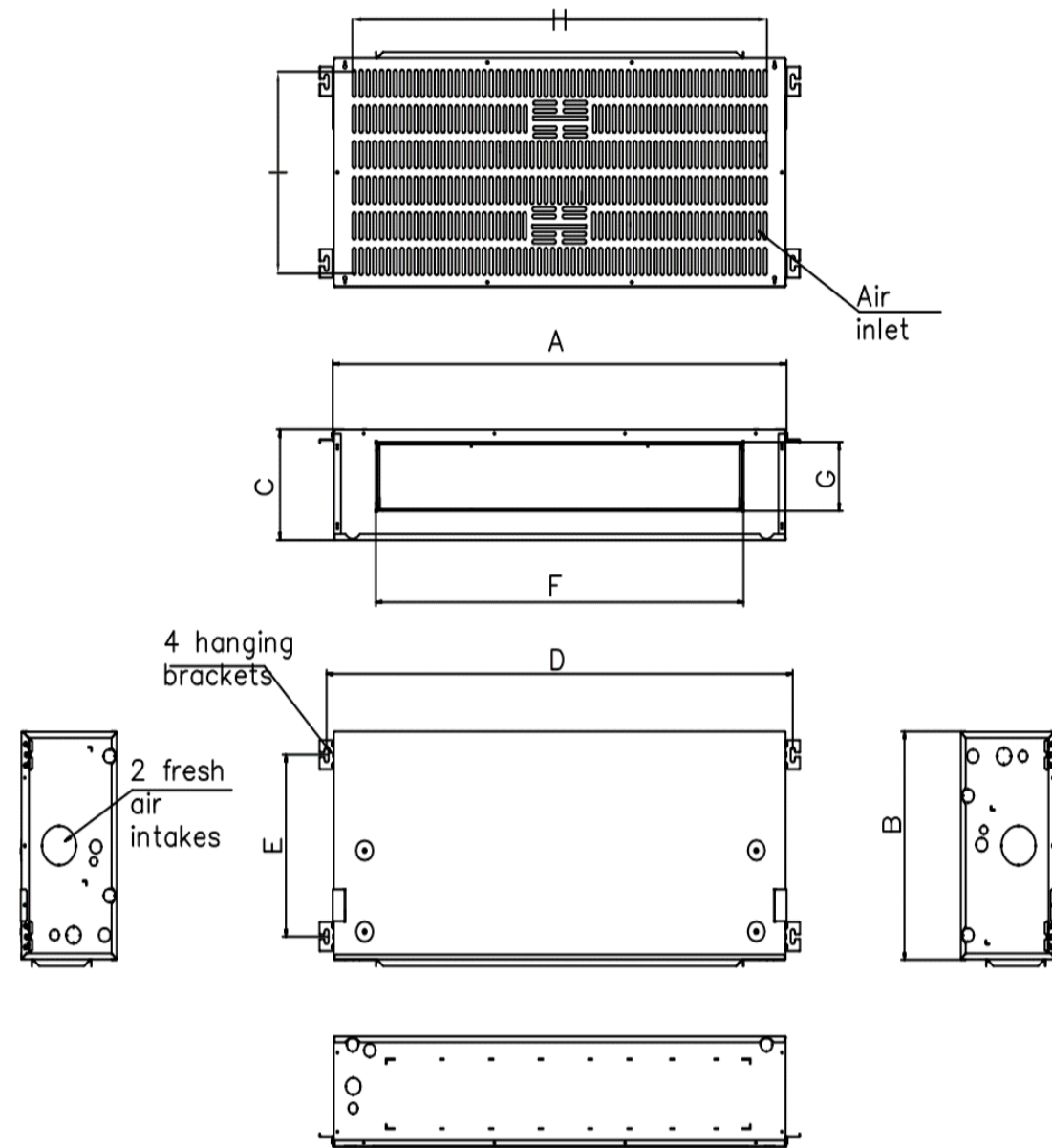

Dimensions	Model(Btu/h)	18K	24K	30K	36K
		inch	inch	inch	inch
A	Model Length	43-1/4	49-1/8	55-1/4	62-1/8
B	Model Width	23-5/16	23-5/16	23-5/16	23-5/16
C	Model Height	10-15/16	10-15/16	10-15/16	10-15/16
D	MOUNTED LUG Length	41-5/8	47-1/2	53-5/8	60-1/2
E	MOUNTED LUG width	18-1/8	18-1/8	18-1/8	18-1/8
F	AIR OUTLET LENGTH	30-5/16	36-3/16	42-5/16	49-3/16
G	AIR OUTLET WIDTH	6-7/8	6-7/8	6-7/8	6-7/8
H	AIR RETURN LENGTH	38-3/8	44-5/16	50-3/8	57-1/4
I	AIR RETURN WIDTH	21-1/8	21-1/8	21-1/8	21-1/8

Outdoor unit dimension

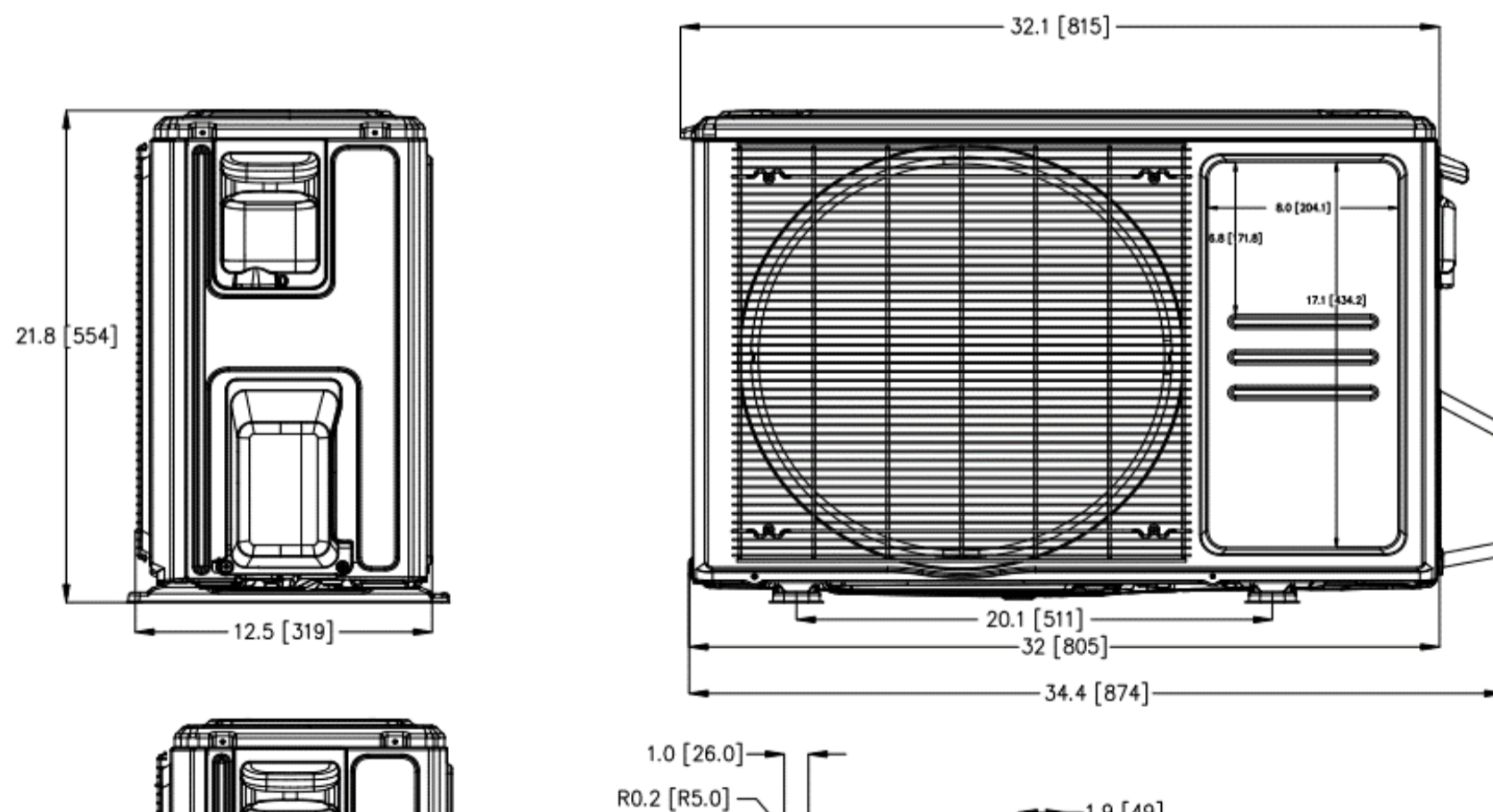

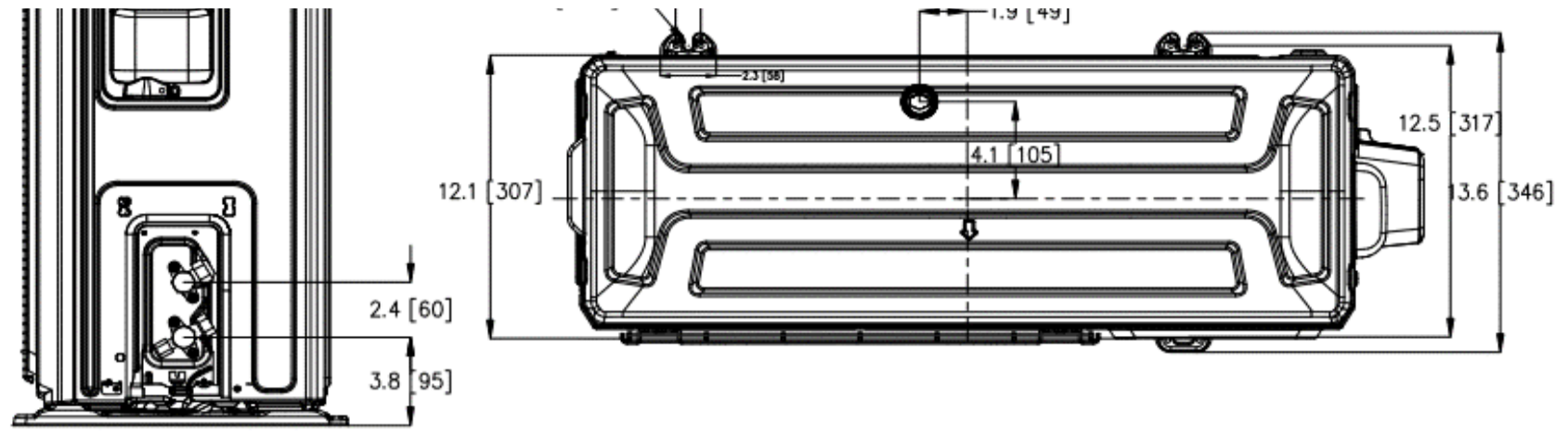

18K

