



SUBMITTAL DATA SHEET

ACIQ-18ZPL-HP230B	18000Btu/h	AHU Heat Pump System
Location: _____	Approval: _____	Date: _____
Engineer: _____	Construction: _____	Unit #: _____
Submitted to: _____	Drawing #: _____	
Submitted by: _____		
Reference: _____		

Set Code	22023110000508
Indoor unit code	22023111000271
Outdoor unit code	22023116000162
Set Model	
Indoor unit model	
Outdoor unit model	ACIQ-18ZPL-HP230B
Certified	<div style="display: flex; justify-content: space-around; align-items: center;"> <div style="text-align: center;"> AHRI </div> <div style="text-align: center;"> </div> <div style="text-align: center;"> </div> </div>



SYSTEM PERFORMANCE DATA		
Power supply		
Normal Operational Voltage	(V, Ph, Hz)	208/230, 1, 60
Voltage Range	(V)	187-253
Electrical		
Minimum circuit ampacity	(A)	16
Max.fuse	(A)	20
Connection wiring		14AWG*2 Stranded, shielded
Cooling		
Rated Capacity	(Btu/h)	18000
Capacity Range	(Btu/h)	6880~21000
Power Input	(W)	1430
Rated current	(A)	7
SEER	(Btu/W)	20
EER	(Btu/W)	12.5
Heating at 47F		
Rated Capacity	(Btu/h)	19000
Capacity Range	(Btu/h)	2800~21000
Power Input	(W)	1550
Rated current	(A)	7
HSPF4	(Btu/W)	11
HSPF5	(Btu/W)	9
COP	W/W	4

REFRIGERANT PIPE DATA		
Throttle type	Indoor unit	EEV for cooling
	Outdoor unit	EEV for heating
Design pressure	(PSIG)	550/340
Refrigerant Type	(Oz)	R410A/81.1
Refrigerant precharge	(ft)	25.0
	(m)	7.5
Additional charge for each ft	(oz/ft)	0.69
	(g/m)	65
Liquid side/ Gas side	(inch)	3/8" / 3/4"
	(mm)	9.52/19
Max. pipe length	(ft)	98.0
	(m)	30
Max. difference in level	(ft)	66.0
	(m)	20
Connection method		Flared
Indoor(cooling/ heating)	(Deg. °F)	60~90/32~86
	(Deg. °C)	16~32/0~30
Outdoor(cooling/heating)	(Deg. °F)	-30~122/-30~75
	(Deg. °C)	-30~50/ -30~24
Application area	(sq.ft)	258.33~376.74
	(m2)	24~35

INDOOR UNIT DATA		
Indoor fan motor		
Type		Centrifugal
Model		ZKFD-250-8-1
Qty		1
Input	(W)	67.8
RLA	(A)	---
LRA	(A)	---
Winding Resistance	(Ω)	---
Capacitor	(uF)	---
Speed(Hi/Mi/Lo)	(r/min)	-
Air flow & Noise level		
Indoor air flow (Hi/Med/Lo) (N)	(CFM)	576.47/529.41/488.24
Indoor noise level (Hi/Med/Lc)	[dB(A)]	36/34/32
Dehumidification		
	(Pint/H)	---
Indoor unit		
Dimension (WxDxH)	(inch)	21.02x17.52x45.00
	(mm)	534x445x1143
Packing(WxDxH)	(inch)	25.20x20.87x50.39
	(mm)	640x530x1280
Net/Gross weight	(lbs.)	105.82/129.41
	(kg)	48/58.7

OUTDOOR UNIT DATA		
Compressor		
Type		Twin-ROTARY
Model		KTM240D57UMT
Brand		GMCC
Capacity	(Btu/h)	24686
Input	(W)	1945
Rated current (RLA)	(A)	-
Refrigerant oil/oil charge	(ml)	VG74/440
Outdoor fan motor		
Model		ZKFN-80-8-3
Qty		1
Input	(W)	88.00
RLA	(A)	--
Speed	(r/min)	800/700/580
Air flow & Noise level		
Outdoor air flow (Max.)	(CFM)	1279.41
Outdoor noise level	[dB(A)]	58
Outdoor unit		
Dimension (W×D×H)	(inch)	35.04x13.46x26.50
	(mm)	890x342x673
Packing (W×D×H)	(inch)	39.17x15.67x29.13
	(mm)	995x398x740
Net/ Gross weight	(lbs.)	102.95/109.79
	(kg)	46.7/49.8

Indoor unit dimension

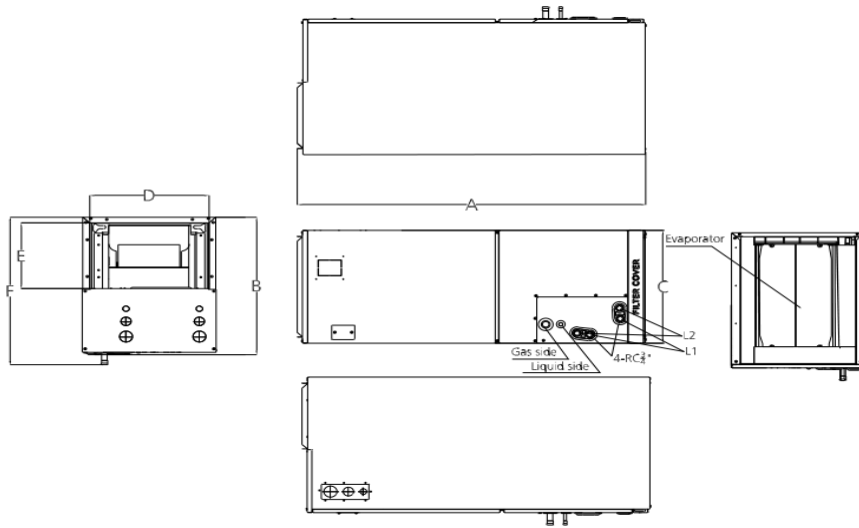

Model	Unit	Dimensions(mm)						Drain hole	
		A	B	C	D	E	F	L1	L2
18k~24k	mm	1143	534	445	400	260	585	Main drain	Overflow drain
	inch	45	21	17-1/2	15-3/4	10-1/4	23		
30k~48k	mm	1245	534	534	490	260	585		
	inch	49	21	21	19-5/16	10-1/4	23		
60k	mm	1346	534	622	580	260	585		
	inch	53	21	24-1/2	22-7/8	10-1/4	23		

Outdoor unit dimension

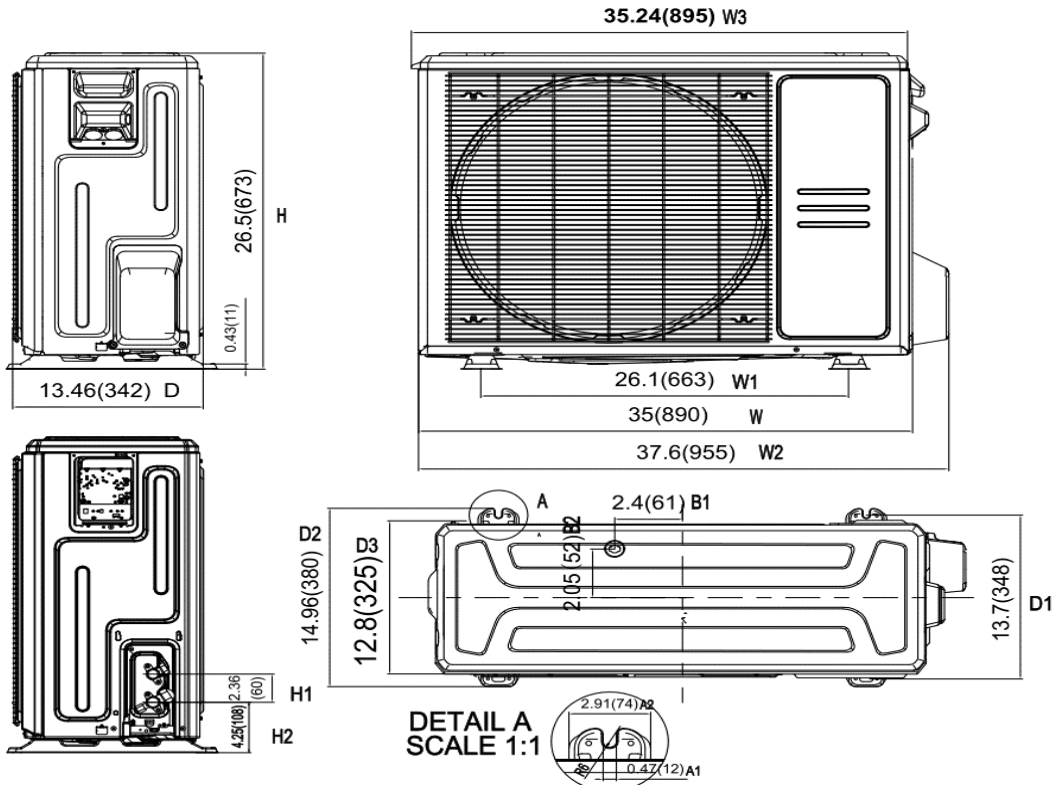

Fan performance

18K

